

Engineered Door Stiles & Door / Window Componentry

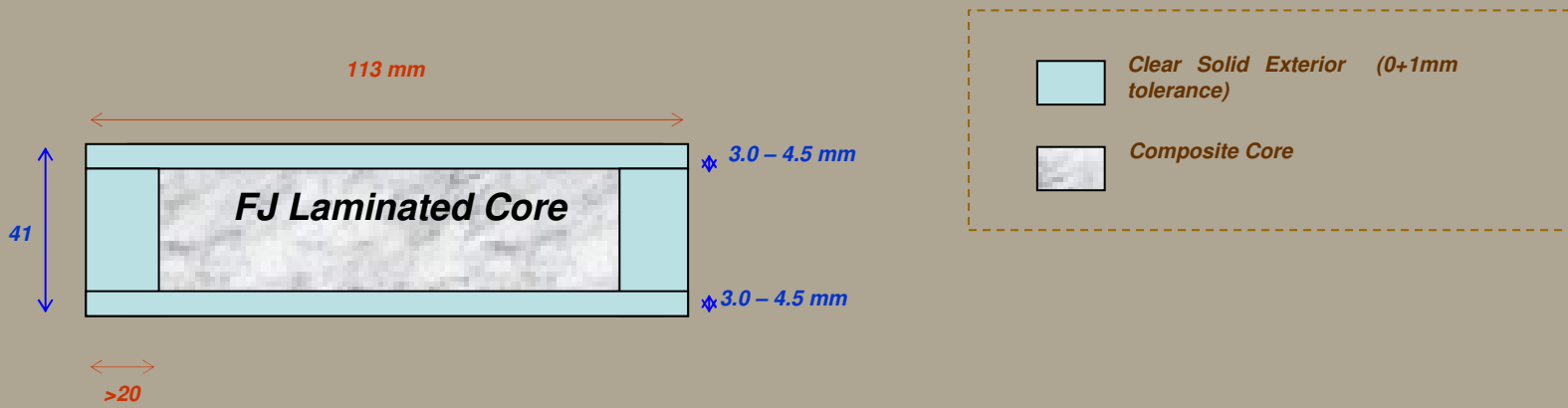

Engineered Door Stiles / Sashes / Componentry

- *Shipment Terms CiF*
- *Outer layer clear grade solid timber in DRM.*
- *Inner core - FJ-laminated*
- *Laminated construction as per drawing above*
- *Material supplied will be well machined & all kiln-dried, 12% MC. We use German Weinig Moulders.*
- *Can be supplied in fixed lengths as per requests, eg 2.1m, 2.4m, 2.7m*
- *Post Machining wood-working includes :*
 - *Precision End-Trim (PET)*
 - *Tenoning*
 - *End-matching*
 - *Dowelling*
 - *Fully assembled door leaf*
 - *Trenching / weather seal*
 - *etc etc*



Next Page Sliding Glass Doors



Finger-Jointed Core –
Unseen surfaces

Premium Grade Outer
layer – visible surfaces





Door Frames supplied fully machined,
Additional woodworking optional :

- (i) dowelling,
- (ii) end-matching,
- (iii) trenching for sliding doors, etc etc